



INSTRUCTION MANUAL
FOR
DIGITAL PRESSURE GAUGE
MODEL ZT60

 NAGANO KEIKI CO., LTD.

MANUAL FOR ACCURATE AND SAFE OPERATION

SAFETY CHAPTER FOR DIGITAL PRESSURE GAUGE

To use these devices accurately and safely, carefully read this manual and the operation manual. Incorrect usage may cause malfunction and result in human injury, accidents, etc.

Be sure to keep this manual for reference after reading.

WARNING

1. Do not apply more than the maximum allowable pressure.
Human injury or damage to surroundings may result due to explosion or breakdown of the pressure elements.
2. Use with the unspecified power supply may cause fire hazard or electric shock.
3. Do not use these devices on measured objects which are corrosive to fluid or gas contacting areas.
Human injury or damage to surroundings may result due to explosion or breakdown of the pressure elements and exposure of dangerous measured objects.
4. Do not apply excessive weight, vibration or shock.
Human injury or damage to surroundings may result due to explosion or breakdown of these devices and exposure of dangerous measured objects.
5. This gauge does not have an explosion-proof construction.
Do not use in dangerous places with flammable gas or fluid liable to cause ignition and explosion.
6. Connect wiring accurately according to the wiring drawings or instructions in the operation manual.
Incorrect wiring may result in human injury or fire hazard.
7. Use with the instrument temperature range.
Use outside the instrument temperature range may cause human injury or damage to surroundings due to explosion or breakdown of the devices.
8. If the measured object is oxygen, use devices with anti-oil treatment.
Standard devices may possibly contain remaining oil, and there is danger of combustion and explosion if oil acts on oxygen.
9. Accurately install these devices according to the installation instructions in the operation manual.
10. Never attempt to reconstruct the main body of devices nor add any new function to the devices, etc. Contact us for repairs.
11. Accurately operate switches according to the operating method described in the operation manual. Incorrect operation may cause malfunction.
12. As this is a precise gauge, keep sources of noise as far away as possible.
Suppress noise with a noise suppressor, etc. When supplying power to this gauge.

Note : Inform us in advance when using these devices in a way that may result in fatal or serious injury due to malfunction or incorrect operation.

CONTENTS

1. General description	2
2. Features	2
3. Specifications	3~4
4. Drawing	5~7
4-1. UC grade	5
4-2. BA grade	6
4-3. ZT60-W02 digital indicator	7
5. Installation and storage	7~11
5-1. Connection to piping	7
5-2. Wiring	8
5-3. Cable specification	8
5-4. Connection of external instruments	9~10
(1) Example of open collector usage	9
(2) Example of analog output (factory shipment option) wiring	10
5-5. Precautions for storage	10
5-6. Precautions to handling	11
6. Modes and their functions	11~12
7. Panel functions	12
8. Selecting basic functions	13~16
8-1. Functions setting mode procedure	13
8-2. Selecting comparator operation mode	14
8-3. Selecting pressure unit	14
8-4. Scaling LED display	15
8-5. Setting filter	15
8-6. Scaling analog output (factory shipment option)	16
9. Adjusting the zero point	16
10. Comparator operation	17~19
10-1. Procedure for comparator setting mode	17
10-2. Operation of hysteresis mode	18
10-3. Operation of window comparator	19
11. Loop Check	20
12. Other functions	20
12-1. Peak Hold	20
12-2. Key Lock	20
13. Error display	21
14. Maintenance	21
14-1. Maintenance	21
14-2. About the influence by the noise	21
15. Others	21

1. General description

The ZT60 digital pressure gauge is for the ultra-clean specifications, which is incorporating a microcomputer, displays pressure on a large LED. It features a comparator, loop check, scaling and many other functions suitable for use with semiconductor processes and high-purity gases.

This is a multifunction type digital pressure gauge with CE marking.

2. Features

- (1) The pressure sensitive part (diaphragm) use Co-Ni alloy sensor, which are extremely corrosion resistant in addition to having high safety and durability levels.
- (2) For UC grade products, the internal surface roughness of gas contact has sub-micron flatness. So it has maximum effect for reducing particles.
- (3) For BA grade products, the surface roughness is about Ry2.5 μ m to keep anti-corrosiveness and air tightness. It is an economy type suited for cost reduction for gas piping.
- (4) 2 outputs of comparators with various functions are mounted. Either the hysteresis mode or the window comparator mode can be selected and also setting of operating point can be selected freely from upper, lower or ON/OFF differential.
- (5) The display scaling function allows setting the value display from -1999 to 6000.
- (6) Scalable analog signal output is available a factory shipment option.
- (7) Zero point adjustment is done in a state of atmosphere released with the one-touch zero adjust function.
- (8) The unit of measurements is selected with ease. It is possible to use the unit in the SI unit or conventional units according to the purpose of the application.
- (9) Loop check function allows output to be changed without pressure application, and it enables simple operation check.
- (10) The filter function allows suppressing the display fluctuation when pressure pulse occurs.
- (11) The peak hold display function allows maximum/minimum values of pressure to be recorded.
- (12) The 4-digit LED display with 8mm high characters is bright and easy to read.
- (13) The vertical and a horizontal display are available for your selection.
- (14) It conforms to EN standards based on EMC directive.(CE marking)

3. Specifications

Fitting configuration		Connections	Pressure ranges	Display value	
S type	Horizontal mount	1 / 4 3 / 8	0 ~ 2 0 0 kPa	2 0 0 . 0	For ZT60-W02 digital indicator, the range is more than 0.5 MPa.
			0 ~ 3 0 0 kPa	3 0 0	
			0 ~ 0 . 5 MPa	0 . 5 0 0	
	Vertical mount	UJR Fitting	0 ~ 1 MPa	1 . 0 0 0	
			0 ~ 2 MPa	2 . 0 0 0	
			0 ~ 3 . 5 MPa	3 . 5 0	
T type	Horizontal mount	VCR Fitting	0 ~ 5 MPa	5 . 0 0	
			0 ~ 1 0 MPa	1 0 . 0 0	
		JSK Fitting	0 ~ 2 0 MPa	2 0 . 0 0	
			- 1 0 0 ~ 1 0 0 kPa	1 0 0 . 0	
		CVC Fitting	- 1 0 0 ~ 2 0 0 kPa	2 0 0 . 0	
			- 1 0 0 ~ 3 0 0 kPa	3 0 0	
			- 0 . 1 ~ 0 . 5 MPa	0 . 5 0 0	
			- 0 . 1 ~ 1 MPa	1 . 0 0 0	
			- 0 . 1 ~ 2 MPa	2 . 0 0 0	
Measurement fluid		Various kind of semiconductor process gases			
Gas contact material		Joint: SUS316L Pressure sensor: Co-Ni alloy			
Treatment		UC grade : Ultra- clean (UC) treatment BA grade : Surface roughness ;Approx. Ry2.5 μ m Degreasing			
Leakage		Less than 5×10^{-12} Pa · m ³ /s (Helium leak test vacuum method)			
Particle		UC grade : Zero count for size 0.1 μ m or greater (In our inspection standard) BA grade : Not specified			
Max. allowable pressure		200% of rated pressure			
Display accuracy		± (1.0%F.S.+1digit) (Standard) or ± (0.5%F.S.+1digit) [0.5MPa or greater can be specified] (Option) ± (0.5%F.S.+1digit) (ZT60-W02)			
Temperature coefficient (ZERO,SPAN)		±0.1%F.S./°C [Accuracy±(1.0%F.S.+1digit)] (Standard) or ±0.05%F.S./°C [Accuracy±(0.5%F.S.+1digit)] (Option)			
Power source		12~24V DC±10% 15~24V DC±10% [In case of 4~20mA DC analog output]			
Consumption current		30mA DC max. 50mA DC max. [In case of 4~20mA DC analog output]			
Analog output (Option)		4~20mA DC (Load resistance 400Ωmax.) or 1~5V DC (Load resistance 10kΩ min.)			
Analog output accuracy		±1.0%F.S. (Standard) or ±0.5%F.S. [0.5MPa or greater can be specified] (Option)			
Comparator output		NPN open collector X 2 output independent (Hysteresis, Window comparator) Max. rating :30V DC, 80mA DC Protective circuit :Over current protection			
ON/OFF delay		0~2 sec. max. (for both ON and OFF)			
Operating temperature and humidity		-10~50°C,35~80%RH (No freezing or condensation)			
Storage temperature		-20~60°C (No freezing or condensation)			
Pressure display		4 digits LED display (Height of letter:8mm)			

Comparator operation display	Red LED (OUT1,2) Light at ON
Measuring units	MPa (kPa) ,kgf/cm ² ,psi,bar,mHg (mmHg) ,etc
Display scaling function	Range of – 1999 to 6000 digit (for rated pressure range)
Analog scaling	Range of – 100 to +200%F.S. (for rated pressure range)
Loop check function	For manual of pressure display, analog output and comparator output irrespective of pressure applied.
Filter function	off,25ms,250ms,2.5s,5s,10s (selectable)
Peak hold display function	Confirmation of Peak value, Bottom value, Reset
One-touch zero adjust function	Press the ADJ.key for more than three seconds. It turns on in one second after letting go of the key.
Key lock function	Lock of operation key
Error display	Over-current, Over-pressure, Error message for adjustment
Protection function	Reverse connection, load short circuit(comparator output)
Weight	Approx.200 ~ 250g
Cable length	2m
Packing	Double packing (UC grade) Single packing (BA grade)
CE marking *	Applicable Directive:2004/108/EC (EMC directive) Applicable Standards: EN61326-1 : 2006 ; EN61326-2-3 : 2006

*:Connect to indoor power distribution network which is not affected by lightning surge voltage and power system switching transients.

4. Drawing
4-1. UC grade

	1/4 UJR	1/4 compatible with VCR
Horizontal mounting T type		
Horizontal mounting S type		
Vertical mounting S type		

4-2. BA grade

	1/4 UJR	1/4 compatible with VCR
Horizontal mounting T type	<p>BA Grade doesn't have screw.</p>	
Horizontal mounting S type		
Vertical mounting S type		

4-3. ZT60-W02 digital indicator

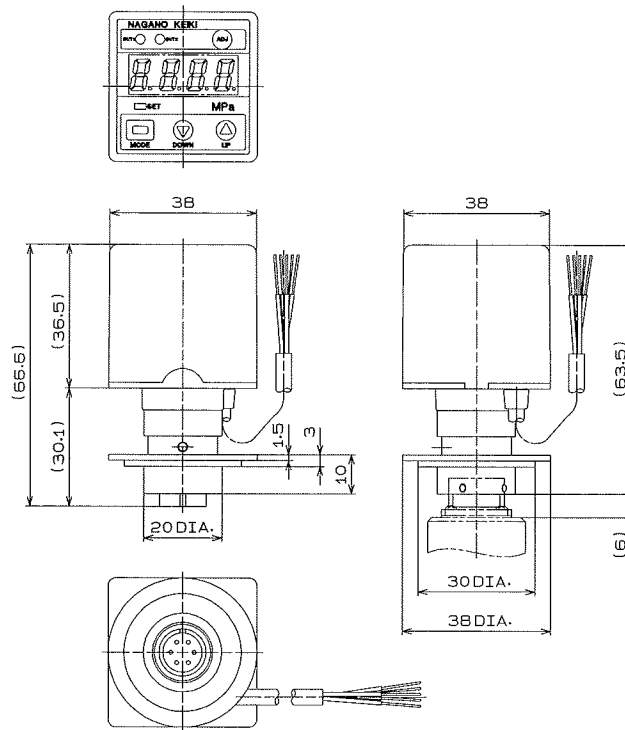

5. Installation and storage

5-1. Connection to piping

Open a sealed bag in clean environment. Do not expose gas contact part to moisture and dust.

Model ZT60 digital pressure gauge is designed for union connection such as UJR, UPG, VCR, JSK and CVC. Do not fail to use the specified gaskets for connection. When installing the unit on the pressure line, do not tighten the case with a pipe wrench, etc. Do not fail use the hexagonal part of the connecting joint or the rectangular (hexagonal) part of the body when installing.

Please be careful in the case of transportation and installation about the following.

Precautions

- This is a finely adjusted instrument. It may become unusable if dropped or if subjected to extreme vibration.
- For installation, select a location without thumping vibration, direct sunlight, and particles.
- Do not touch or breathe to the gas contact parts. Also, please be careful not to damage the sealing surface.
- Do not apply any excessive shock to the case at the time of installation.
- Do not use unreasonable force or bend the leads extending from the unit.
- Do not conduct snoop test to the sensor. It may deteriorate insulation resistance.
- It is recommended to purge the device with enough inert gas, to remove atmospheric compositions, particles, foreign materials and others are removed.

5-2. Wiring

Cable color is identified as follows.

- (1) Standard (no analog output)
 - Brown Power source (+)
 - Blue Power source (-)
 - Black Open collector output (OUT1)
 - White Open collector output (OUT2)

- (2) Analog output (with 4 to 20mA DC or 1 to 5V DC)
 - Brown Power source (+)
 - Blue COMMON
 - Black Open collector output (OUT1)
 - White Open collector output (OUT2)
 - Orange Analog output (+)

Keep the following in connecting work

Precautions

- Do not pull cables with excessive force. Do not bend cables excessively.
- When installing this gauge, determine the rating of power source device to be used after confirming the ratings in the specification.
- When soldering, make sure soldering iron does not touch cases and sheaths.
- When analog and comparator outputs are not used, please treat each wire so that it does not short-circuit.

5-3. Cable specifications

Specifications for connecting cables are as follows:

Use connectors which conform to the specification below.

- Conductor OD : Approx. 0.54mm (25AWG)
- Insulator OD : Wire sheaths (Brown, Blue, Black, White, Orange) ...Approx.0.86mm / Coat (Black) ...Approx.4.0mm

5-4. Connection of external instruments

Output Type: The comparator output comprises open collector output. The analog output (factory shipment option) comprises 4 to 20mA DC current output or 1 to 5V DC voltage output.

"Open collector" means that the collector of an output transistor is open for the user to use for any desired user defined application. Accordingly, the user is free to use the open collector output in any way. Three typical applications are described below.

The output transistor is rated for 30V DC, 80mA DC. Be sure not to exceed this rating.

(1) Example of open collector usage

① Relay connection

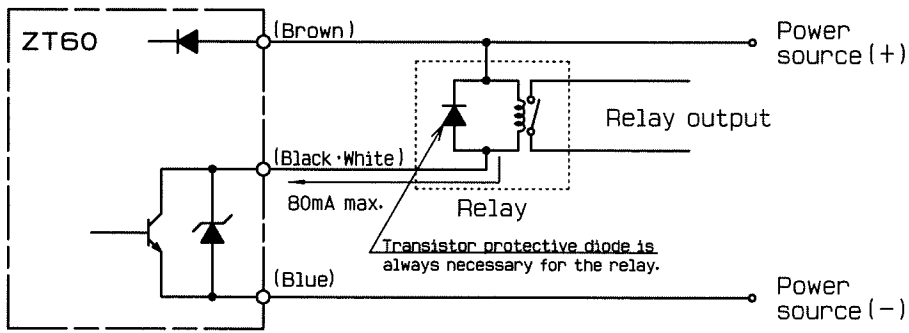

Note : Rated current and voltage for the relay coil must be within the rating for the transistor.

② Photo coupler connection

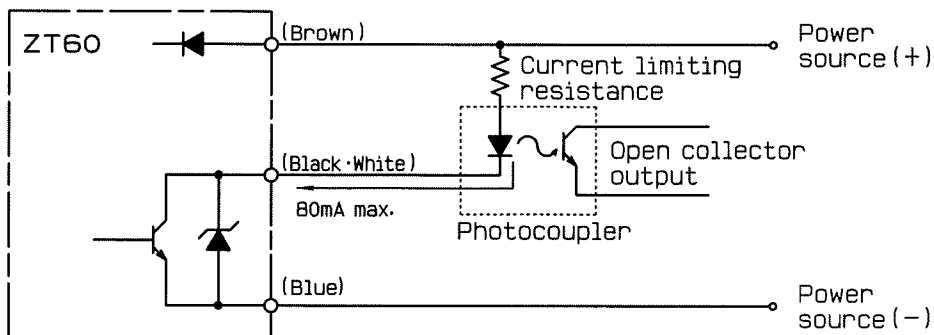

③ Voltage output

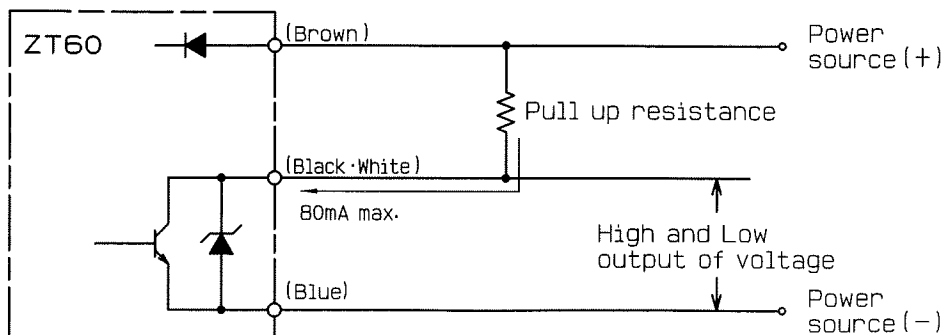

(2) Example of analog output (factory shipment option) wiring

① 4 to 20mA DC

This is exclusively used as source. Never connect to the power source (+).

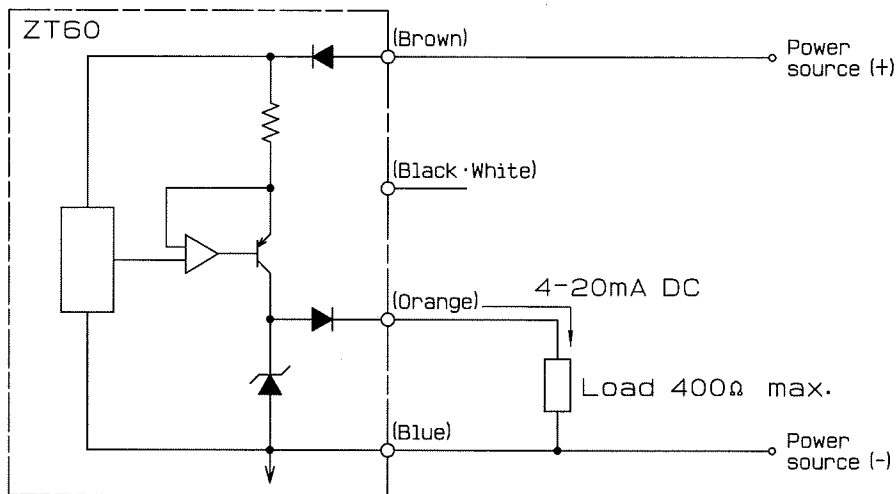

② 1 to 5V DC

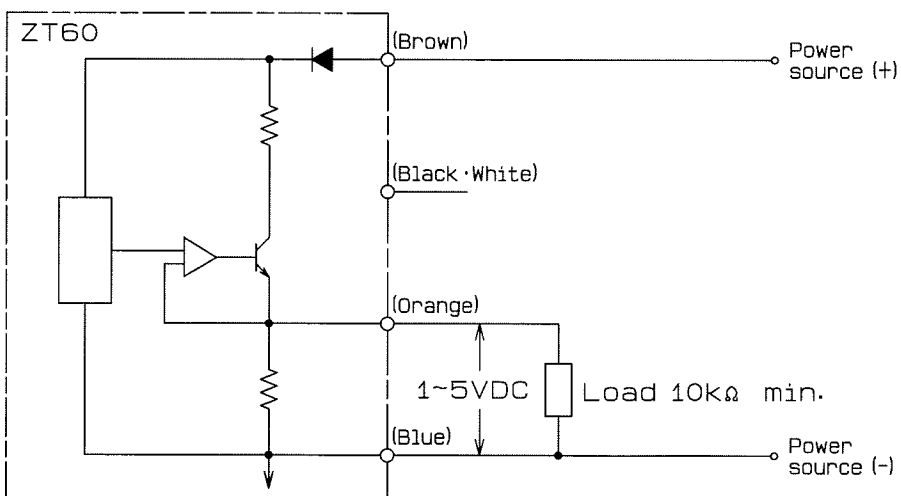

5-5. Precautions for storage

 Caution	<p>Do not store this pressure gauge in the following place as damage may be caused.</p> <ul style="list-style-type: none"> ○ Exposed to water. ○ Susceptible to air pressure, temperature, humidity, ventilation, sunlight, particles, salt or sulfur in the air. ○ Exposed to inclination, vibration or shock (including transportation time). ○ Exposed to chemicals (chemicals' storage area) or gas. ○ Exposed to direct sunlight or high temperature.
---	---

5-6. Precautions to handling

Before power on the device, make sure the wire connection is correct and confirm voltage rating and current rating of power source device, and that the inner electrical resistance of externally connected devices does not exceed load resistance of the main body.

Power on and after **15 minutes or more warm-ups** in current-carrying status, perform zero adjustment then start main operation. Caution the followings during operation.

Precautions

- ZT60-W02 digital indicator has to be combined with Constant Output ZT17 Pressure Transducer. When combining the two, please check the range.
- Do not increase pressure above the level displayed on the ZT60 label.
- The display of the horizontal mount type or ZT60-W02 can be turned within 90°. Do not apply excessive force to turn it. Additionally, the display should be allowed to turn only at setting, do not turn without necessity.
- After using the unit for corrosive gas, do not fail to purge it with nitrogen gas, etc. before removing the unit for maintenance etc. If it is removed and left as it is with corrosive gas inside, the water content and oxygen in the air will generate strong acid and alkaline substances, which accelerate corrosion of the internal parts of the unit.
- To set pressure, refer to the comparator setting procedures on pages 17 to 19, and set the system to the desired level.

6. Modes and their functions

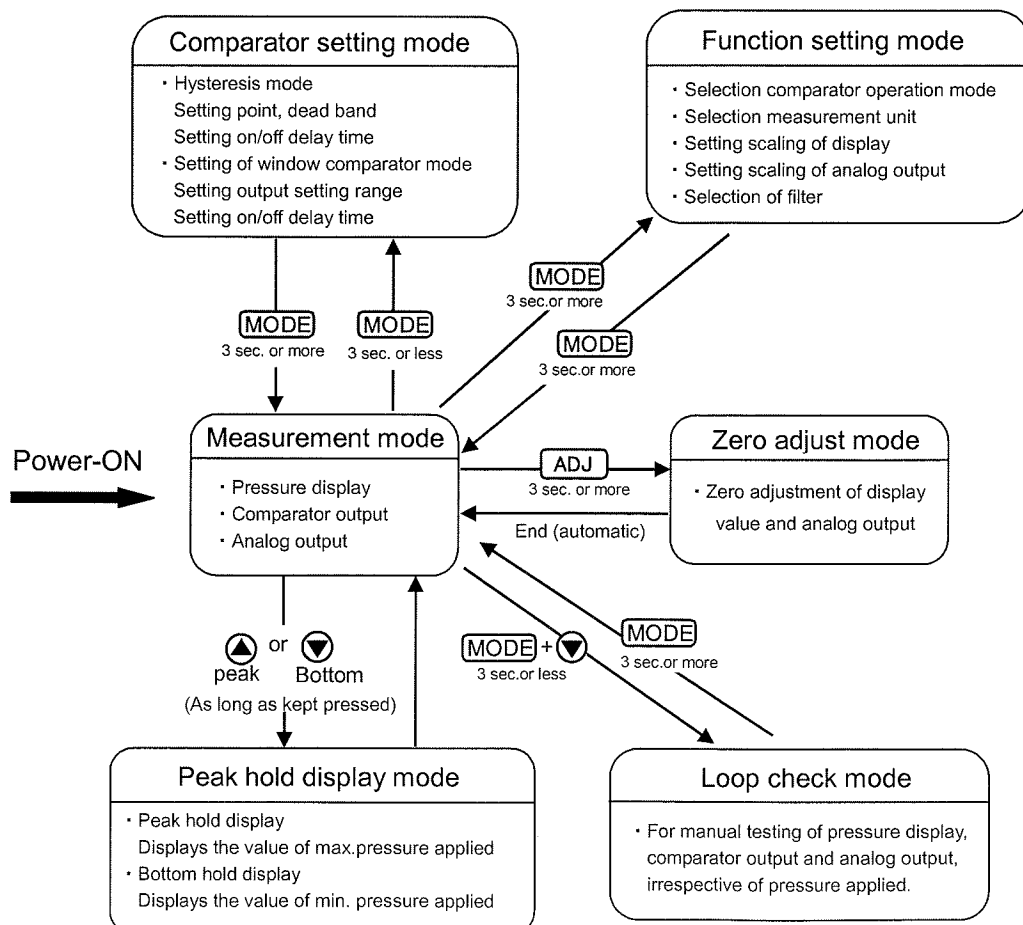

* Setting value back-ups

This device has built-in EEPROM. Main set value and operation status are maintained while power is off.

【Maintained contents while power is off】

- Stored set value : All set values of function and comparator setting modes.
- Stored status : keylock and unlock status.

7. Panel functions

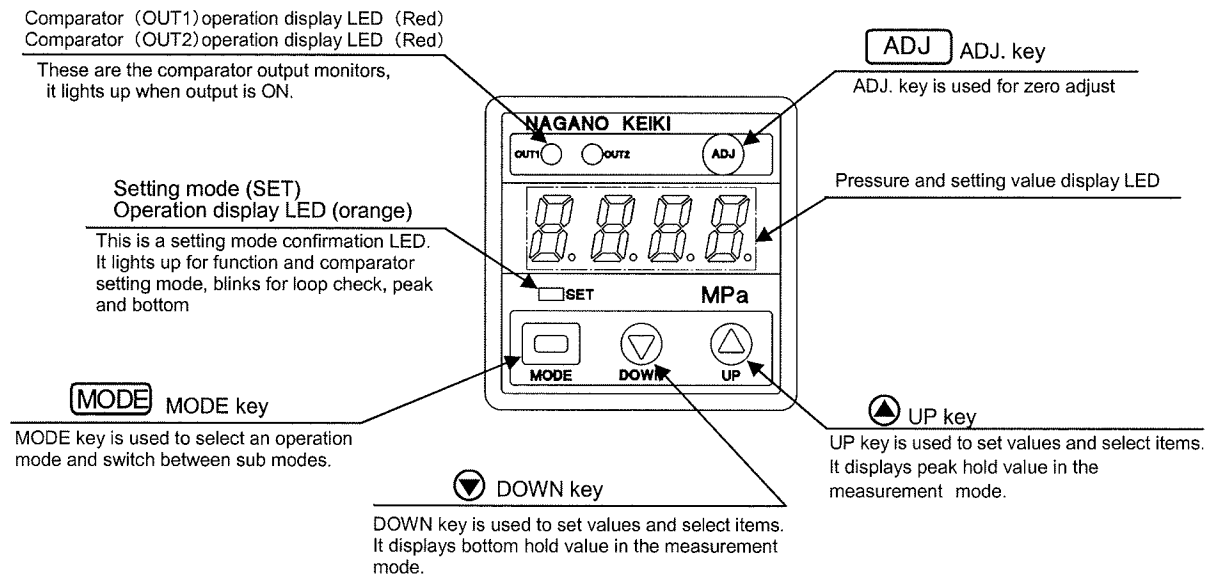

Precautions

- To avoid making a hole on the panel, make sure not to pose excessive force or to press keys with edged tools.

*Basic Key Operations

When **MODE** key or **ADJ** key is pressed, "----" is always displayed.

When those keys are pressed, SET LED starts blinking showing the three seconds have passed.

In all setting mode, values are set with the **▲▼** keys. Use **▲** key to increase and **▼** key to decrease the value. Pressure and keep the **▲▼** key pressed for more than 0.5 sec., and the value increases or decreases at the high speed of three levels.

The **▲▼** keys are also used for setting comparator, unit and filter in the function setting mode.

8-2. Selecting comparator operation mode

Select "Selecting Comparator Operation Mode" with the **MODE** key. The message **Comp** is displayed for one second and then the current operation mode is displayed. Select either Hysteresis or Window Comparator Operation with the **▲▼** keys.

8-3. Selecting pressure unit

Select "Selecting Unit" with the **MODE** key.

The message **Unit** is displayed for one second and then the current unit is displayed. Select the unit with the **▲▼** keys. When the operator selecting **ELL**, the LED display is scaled by the value set in the display scaling. The analog output is not scaled.

Please see paragraphs 8-6 (page 16/21) about scaling analog output.

[Pressure range and display unit]

Pressure range Min. Max.	Max. pressure display value							Display scaling etc
	mmHg	kPa	psi	kgf/cm ²	bar	mHg	MPa	
0~200kPa	1500	200.0	29.01	2.039	2.000	—	—	
0~300kPa	2250	300	43.5	3.06	3.00	—	—	
0~0.5MPa	—	—	72.5	5.10	5.00	3.75	0.500	
0~1MPa	—	—	145.0	10.20	10.00	7.50	1.000	
0~2MPa	—	—	290.1	20.39	20.00	15.00	2.000	
0~3.5MPa	—	—	508	35.7	35.0	26.25	3.50	
0~5MPa	—	—	725	51.0	50.0	37.5	5.00	
0~10MPa	—	—	1450	102.0	100.0	75.0	10.00	
0~20MPa	—	—	2901	203.9	200.0	150.0	20.00	
-100~100kPa	750	100.0	14.50	1.020	1.000	—	—	
-100~200kPa	1500	200.0	29.01	2.039	2.000	—	—	
-100~300kPa	2250	300	43.5	3.06	3.00	—	—	
-0.1~0.5MPa	—	—	72.5	5.10	5.00	3.75	0.500	
-0.1~1MPa	—	—	145.0	10.20	10.00	7.50	1.000	
-0.1~2MPa	—	—	290.1	20.39	20.00	15.00	2.000	

8-4. Scaling LED display

When the operator selects **U n i t** in the selection of unit, the LED value for applied pressure is scaled to any desired value. This function is used change the LED display for minimum/maximum pressure range within the range of -1999 to 6000 digit with respect to the rated pressure range (displayed on the product label). It does not affect the relation between applied pressure and analog output.

Select "Display Scaling" with the **MODE** key. The message **d 5 - P** is displayed for one second and then the decimal position for the current pressure display is displayed. Change the value with the **▲ ▼** keys.

Set the display value for min. /max. pressure range is stored internally as arithmetic coefficients. From this time on, whenever you select the unit **U n i t**, the value is scaled by this coefficient and LED displayed.

Example: The 0.00 to 1.000MPa display for pressure range 0 to 1MPa (0 to 100%F.S.) is changed to the 0.00 to 10.20 display.

U n i t	Selection of measurement unit	: MPa	→	etc
d 5 - P	Position of decimal point (from the least digit)	: 0.003	→	0.02
d 5 - L	Display value for minimum pressure range	: 0.000	→	0.00
d 5 - H	Display value for maximum pressure range	: 1.000	→	10.20

8-5. Setting filter

This device has built-in digital filter with 5 types of time constant. Use this setting when it hard to read display due to pressure pulses. The filter selected in this setting procedure is effective immediately after A/D conversion so that the time constant is reflected also on the comparator and analog output.

Select "Setting Filter" with the **MODE** key. A message **F i l t e r** is displayed for one second and then the current setting is displayed. Select a new filter time constant with the **▲ ▼** keys.

F L - 0No filter	
F L - 125ms time constant	
F L - 2250ms time constant	F L - 45s time constant
F L - 32.5s time constant	F L - 510s time constant

Example: Setting the filter at 25ms time constant

No Filter **F L - 0** → **F L - 1** Select **▲ ▼** keys. 25ms time constant

8-6. Scaling analog output (factory shipment option)

This function is used to change the zero point (4mA DC or 1V DC)/span point (20mA DC or 5V DC) of analog output within the -100 to 200%F.S. range with respect to the rated pressure range (displayed on the product label).

However, the impressed pressure reaches 110%F.S. of the range, the error message **FFF** is displayed.

Select "Analog Scaling" with the **MODE** key. A message **RS-L** is displayed for one second and then the pressure corresponding to the current analog output zero point (4mA DC or 1V DC) is displayed in a percentage of the full scale of the pressure range. Enter the desired value with the **▲▼** keys.

Set the pressure for analog output span point **RS-H** in like manner using the **MODE** key and **▲▼** keys.

Example: The unit of 4 to 20mA DC output with pressure range 0 to 1MPa (0 to 100%F.S.) is changed to 4 to 20mA DC output with 0 to 0.981MPa.

RS-L Pressure at analog output zero point: 0.0%F.S. \longrightarrow 0.0%F.S.
(Will output 4mA DC with pressure range 0%F.S.)

RS-H Pressure at analog output span point: 100%F.S. \longrightarrow 98.1%F.S.
(Will output 20mA DC with pressure range 98.1%F.S.)

9. Adjusting the zero point

Open the pressure port to the atmosphere in the measurement mode and press the **ADJ** key for more than three seconds (till SET LED flashes), then release the **ADJ** key. About after a second the automatic zero adjustment is done to adjust the pressure display zero.

A message **0Adj** is displayed when the zero point adjustment is successful.

When the pressed pressure is more than $\pm 10\%$ F.S., the error message **Errr** is displayed for a second, and no zero adjustment is done.

Precautions

- Before the zero adjustment, first power on the device and warm up for 15 minutes or more with current applied.

10. Comparator operation

The comparator incorporates two points of OUT1 and OUT2. For each of them, you may collectively select and set two kinds of operation modes of “Hysteresis (upper/lower limits)” and “Window comparator”. For both modes, you may set a maximum of two seconds of On/Off delay time for OUT1 and OUT2 individually. When the comparator output conditions are satisfied as described below, respective outputs enter into the ON state and the Monitor LED (OUT1, OUT2) is lighted.

10-1. Procedure for comparator setting mode

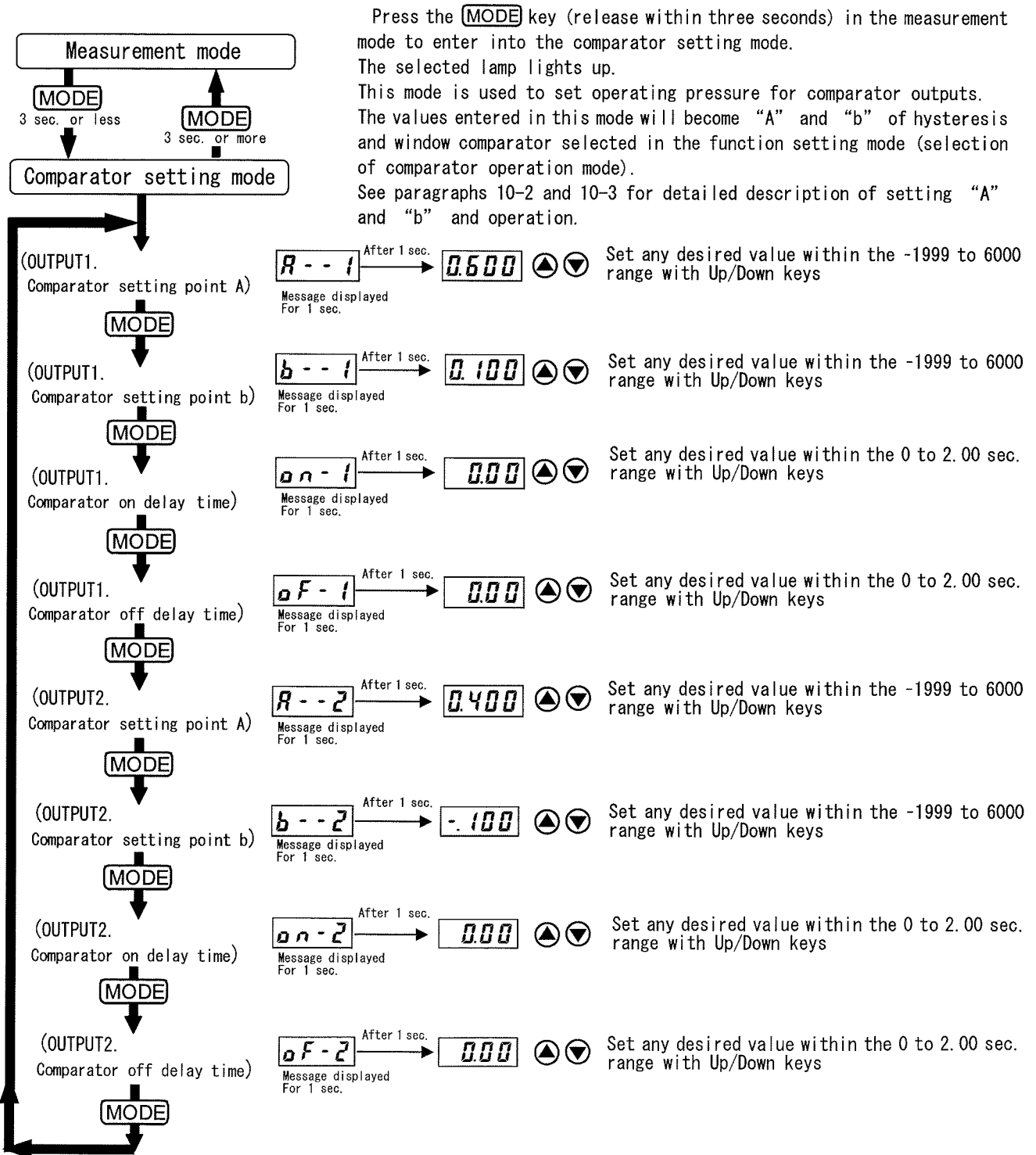

Caution: The values shown above are factory default values where pressure is 0 to 1 MPa.

These values differ depending on pressure range. Set them at desirable value to use.

Also, please set the comparator's setting value within the range of rated pressure, [-10 to +100%F.S.].

10-2. Operation of hysteresis mode

• Setting the upper limit

This is the mode in which the comparator operates with the setting item (A) as the upper limit. The upper limit setting is determined when you select a positive figure (including 0) for setting item (b).

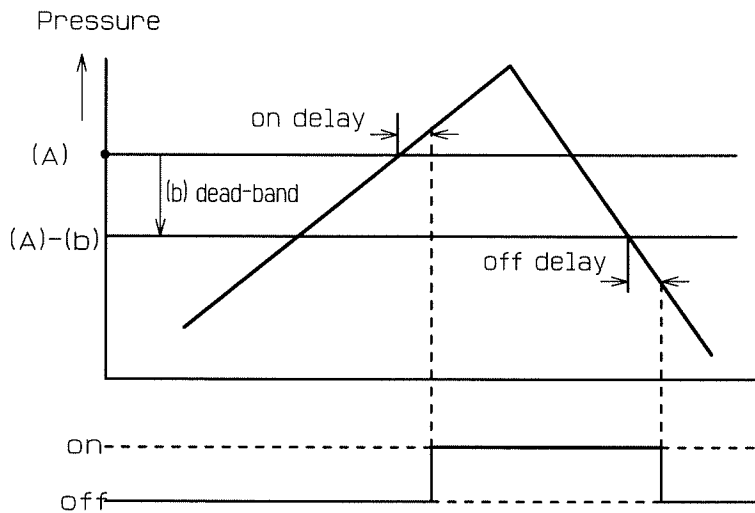

• Setting the lower limit

This is the mode in which the comparator operates with the setting item (A) as the lower limit. The lower limit setting is determined when you select a negative figure for setting item (b).

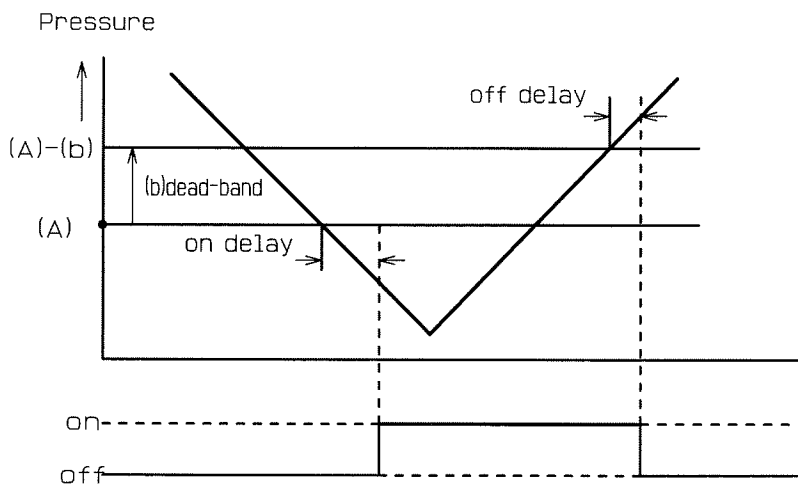

Precautions

The comparator might start chattering when the pressure is showing unstable condition such as pulsation, and also when the setting of dead-band is small.

In such case, take the system safety measures as well as using the filter function and the delay timer (on, off delay) function.

When dead-band is set zero, the operation could get unstable. It is recommended to set the hysteresis more than 1%F.S.

10-3. Operation of window comparator

For (A) < (b)

Pressure

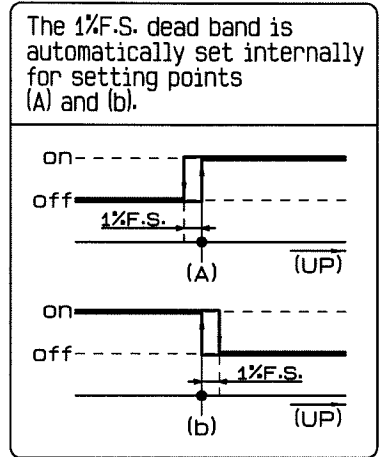
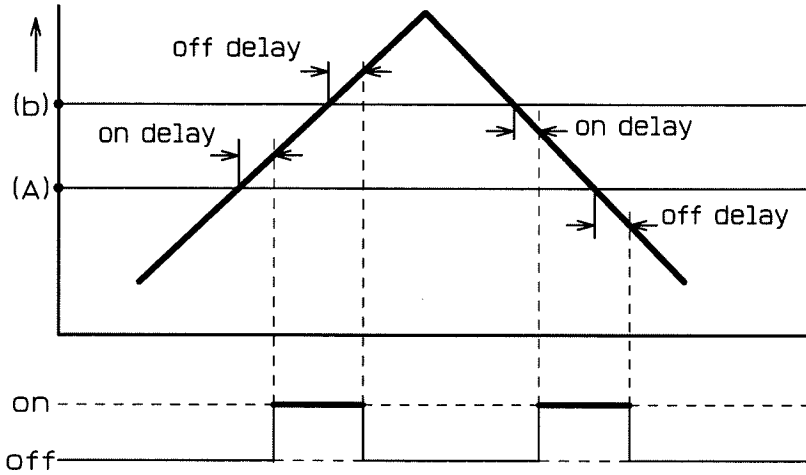

For (A) > (b)

Pressure

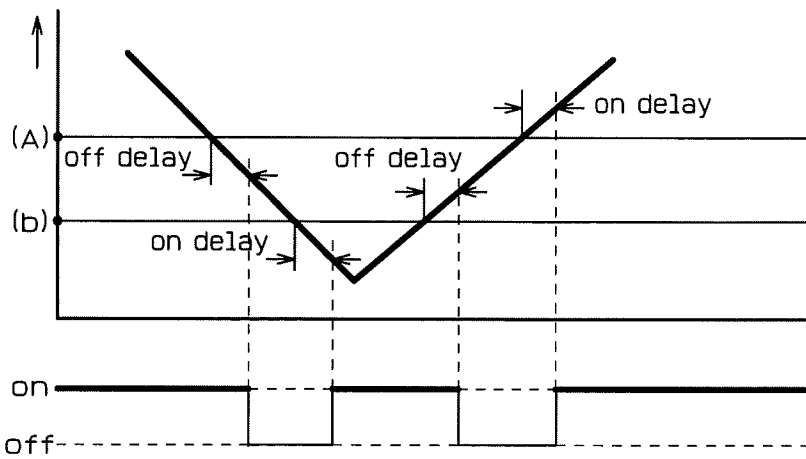

When the ON and OFF delay time is set, the delay time counting starts from where 1%F.S. of initial setting is exceeded.

Accordingly, the delay time will be 1%F.S. + setting delay time.

11. Loop check

Display and analog / comparator outputs can be tested by pressing \blacktriangle \blacktriangledown keys manually without applying pressure. Use this function for the simulation of wiring check, etc. of analog output.

Press the **MODE** key and \blacktriangledown key in the measurement mode. A message **LoOp** is displayed for one second, indicating that you have entered into the loop check mode. The Selected light blinks.

The operator can change the pressure indication value manually with the \blacktriangle \blacktriangledown keys. The analog and comparator outputs also vary in accordance with the display. Press the **MODE** key for more than three seconds to return to the measurement mode.

12. Other functions

12-1. Peak hold

The ZT60 unit keeps the maximum and minimum pressure level applied to the pressure port as peak and bottom value, respectively, in the internal memory. The peak and bottom values are displayed as long as you press and keep pressed the \blacktriangle and \blacktriangledown keys, respectively. When you select this operation, a message **PEAK** is displayed for one second and "SET LED" lamp blinks. Peak and bottom values are reset when you remake power for the unit or in the following procedure:

Reset of peak value : Press \blacktriangledown key with \blacktriangle the key pressed.

Reset of bottom value: Press \blacktriangle key with \blacktriangledown the key pressed.

12-2. Key lock

You may nullify the key operations to prevent inadvertent overwriting of setting values.

Once the key lock state is set, you cannot go to the function setting, comparator setting, zero point adjust, and loop check modes. The key lock state is not reset by remaking power. It may be reset only by the following unlocking procedure.

Press **MODE** key and \blacktriangle key in the measurement mode. A message **LoLk** is displayed for one second, indicating that the unit has entered into the key lock state.



To reset, also press **MODE** key and \blacktriangle key. A message **UnLk** is displayed for one second, indicating that the unit is unlocked.

* Basic item on combination key operation

Combination key operation means to operation means to operate by pressing key ① and key ② when doing this press key ① and then key ② within three seconds.

13. Error display

An error message and a pressure are alternately displayed when one of the following errors occurs while you are in the measurement or loop check mode.

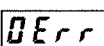
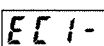
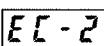
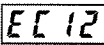
Error display	Contents	Procedure
	Occurs when the pressure range modulates over 110%F.S. or the display passes 6000.	Adjust the applied pressure within the rated pressure.
	Occurs when the pressure range modulates below -10%F.S. or the display goes below -1999.	
	A pressure equal to or above $\pm 10\%$ F.S. of sensor range is applied when adjusting zero point	Open the unit to the atmosphere and adjust zero point again
	Comparator 1 is overloaded.	Please limit load current up to 80mA DC to use. To recover from an error, check the wire connections and rating of the connected instruments then turn on the power again.
	Comparator 2 is overloaded.	
	Both comparator 1 and 2 are overloaded.	

* Contact us when an error is displayed after taking action.

14. Maintenance

14-1. Maintenance

Basically, this device does not have mis-adjustment. However, considering aging phenomena, it is recommended to implement regular check once in a half year. Also, please calibration in decided method or calibration organization. Refer following checklist for periodical inspection.

【Checklist for periodical inspection】

- External appearance.
- Insulation between each terminal and case (measure with 100M Ω or more/50 VDC or less).
- Leak test of piping connection part.
- Output check by standard pressure instrument.

14-2. About the influence by the noise

Since there are various noises, it is difficult to take perfect measures against all noises.

If output values are fluctuated from time to time or wrong values are continuously displayed, it may be affected by noise.

To take measures against noise, it is necessary to identify the source, route and type of noise.

- To take countermeasure against the radiated noise from wireless devices such as transceiver, measures with ferritic core/metal conduit, or filter that has three-terminal capacitor/lead-through capacitor are effective.
- To take countermeasure against the inductive noise due to drawn cables, etc., separation of power line from signal wire or isolation by individual conduit, or use of twisted pair wire are effective.
- To take countermeasure against conductive noise such as switching power source or inverter, low-pass filter or filters with built-in common mode choke coil are effective.

These countermeasures can reduce the effect of noise for certain degrees but there may be some cases that the intended effect is not achieved.

Basically, to eliminate or keep away the source of noise is most effective.

15. Others

This manual cannot cover all details of the instrument or all other variations; nor does it aim to explain all details of installation, maintenance and all other subjects. If you need more information, please feel free to contact us. The contents of these instructions are subject to change without notice.