



GC30  
Digital Differential Pressure Gauge  
Operation Manual

NAGANO KEIKI CO., LTD

2004.02.12

## For safety of use

In order to safely and correctly utilize this device, please read this instruction manual to the end. Incorrect operation can result in malfunction, damage or an accident.

 <b>Warning</b>	Indicates that as a result of incorrect use of the GC30, severe injury or loss of life can occur.
--	---

 <b>Note</b>	Indicates that as a result of incorrect use of the GC30, damage or malfunction can occur.
---	---

 <b>Warning</b>	<ol style="list-style-type: none"> <li>1. Do not use pressure greater than the maximum allowable. pressure. This can cause the pressure element to break or be damaged as well as causing injury or damage to the surroundings.</li> <li>2. Use of a non designated power source can cause a fire or electrical shock.</li> <li>3. Use only dry air or nitrogen for measurement.</li> <li>4. Do not use where extreme weight, vibration or impact can occur. This can cause the unit to break or be damaged which can cause a release of the measurement gas causing injury or damage to the surroundings.</li> <li>5. The GC30 is not explosion-proof. Do not use in areas where flammable or explosive gases or liquids are located.</li> <li>6. Perform wiring according to the wiring diagram on the faceplate or in the operation manual. Incorrect wiring can cause injury or damage to the surroundings.</li> <li>7. Use within operating temperature range. Using outside the operating temperature range can cause the unit to break or be damaged as well as causing injury or damage to the surroundings.</li> <li>8. Perform the installation according to the outline in the operation manual.</li> <li>9. Do not take apart, repair or convert this unit. Contact the manufacturer for repairs.</li> <li>10. Perform operation of the switches according to the operation manual. Incorrect operation can result in malfunction.</li> <li>11. The GC30 is a precision electronic instrument so ensure that the unit's power supply does not come in contact with noise disturbance from main power sources. In cases where noise disturbance can occur, a noise filter is recommended.             <ul style="list-style-type: none"> <li>※ Please do not use GC30 when the breakdown and the malfunction of this container threaten the life directly or harm might be caused for the human body.</li> </ul> </li> </ol>
--	---

Nagano Keiki does not take responsibility for damage or physical injury caused by the following:

- Repairs or alterations by other companies
- Use of products from other companies that cause damage
- Use of non authorized parts for maintenance causing damage
- Non compliance with the precautions in these instructions or improper use service conditions
- Fire, earthquake, water damage or other natural disaster

## CONTENTS

1. Specifications .....	2
2. Outline drawing.....	4
3. Installation.....	5
4. Connection.....	7
5. Noise prevention.....	9
6. Storage location.....	9
7. Maintenance.....	9
8. How to move to each mode.....	10
9. Function setting mode.....	11
10. Comparator setting mode / Loop check mode.....	15
11. Comparator operation .....	17
12. Other functions .....	19

## 1. Specifications

Differential pressure range (indication max.)		Indication accuracy	Temp. coef. (Zero-span)
0~50 Pa (50.0)	±50 Pa (50.0)	±(2.0% F. S. +1digit)	±0.15% F. S. /°C
0~100 Pa (100.0)	±100 Pa (100.0)		
0~200 Pa (200)	±200 Pa (200)		
0~500 Pa (500)	±500 Pa (500)	±(1.5% F. S. +1digit)	±0.10% F. S. /°C
0~1 kPa (1.000)	±1 kPa (1.000)	±(1.0% F. S. +1digit)	
0~2 kPa (2.00)	±2 kPa (2.00)		
0~5 kPa (5.00)	±5 kPa (5.00)		

Display range	Diff. press range of - 10 to 110%F.S. or Display of -1999~1999
Max. allowable pressure	50kPa
Applicable liquid	Non-corrosive gas, such as dry air, nitrogen (not including water or dust) Please inquire regarding other applicable liquids.
Environ. used	Under normal conditions, do not use a location where flammable or explosive gasses or liquids are present.
Connect. screw	M5 female screw
Power source	12 to 24V DC ±10% ripple voltage 10% (P-P) following
Current consumption	Less than 30mA DC
Display	Pressure display 3 1/2 digit LED (figure height: 10mm) Operaing display light Red LED (lit when ON)
Cycling time	0.2s
Output	Comparator output NPN Open collector 2 output Response Time : Less than 5ms Output capacity : 30V DC, 80mA max. Dead band : Hysteresis : variable Window comparator : 1%F. S. fixed Delay : 0 to 2.00s (both ON, OFF)
	Analog output 1 - 5V DC Output accuracy : ±1.5% F. S. for indication Response Time : Less than 50ms Resolution : Approx. 30mV DC Load resistance : 10kΩ min.
Heat run time	More than 15 min. (30 min. recommended)
Operating temp. range	- 10 to 50°C (non freezing)
Operating humid. range	35 to 85%RH (with no condensation)

Storage temp. range	- 20 to 60°C (non freezing)
Leakage tolerance	$1.70 \times 10^{-4} \text{ Pa} \cdot \text{m}^3/\text{s}$
Case construction	IP40 (interior use)
Case material	PC/ABS
Cable length	2m
Weight	Approx. 75g (including 2m cable)
Accessory	4 DIA. Barb for tube (only GC30-111) Panel adapter · L type clamp (option)

## 2. Outline drawing

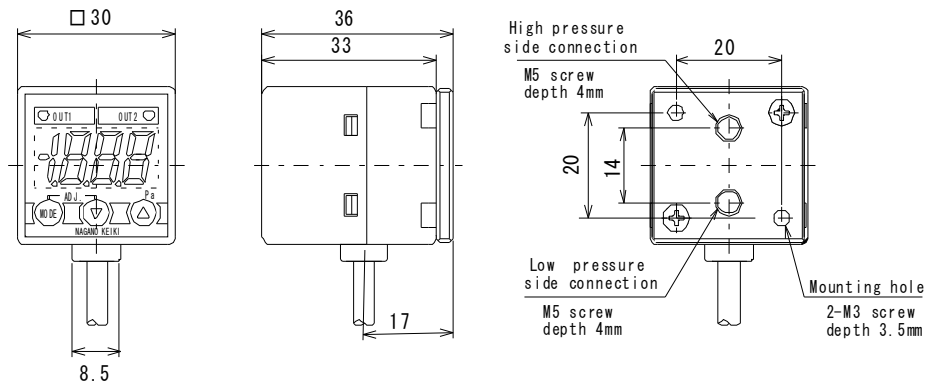
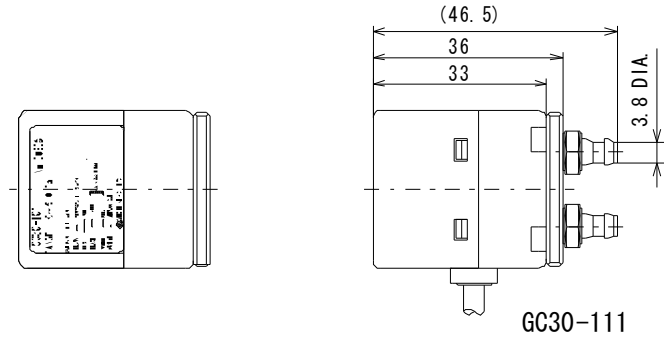

L type clamp (option)

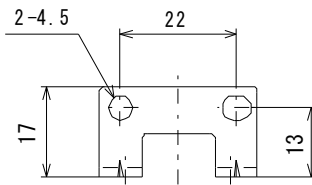
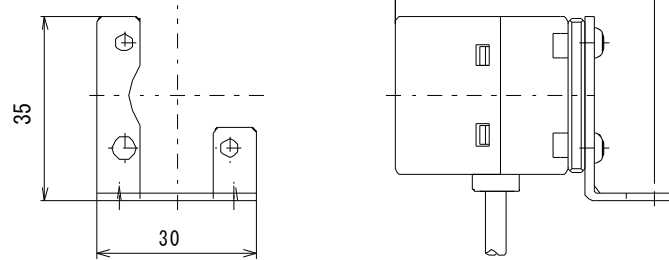
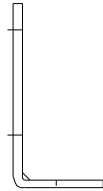

Adapter for panel mount (option)

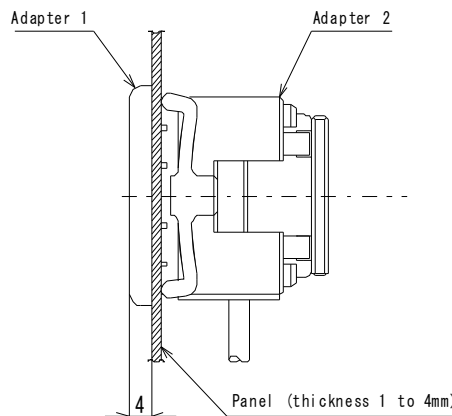
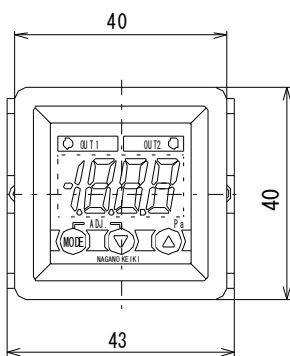

Panel cutout dimensions

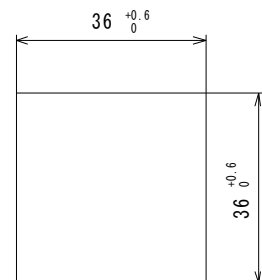

### 3. Installation

Install in a location where there is no vibration, no direct sunlight, little moisture or dust, and where oil or water etc. cannot reach. When the pressure port is used as a ventilation hole, avoid locations where the unit can come in direct contact with wind. If the GC30 is installed in such a location, use a tube etc. for the ventilation to reach an area with no pressure changes.

As this unit is made of plastic, take proper precautions to avoid excess force or scratches. Also, if the rear plate is removed leakage can occur. Do not loosen the screws.

- Pipe laying

When installing the accessory Barb joint (GC30-111), after tightening by hand use a wrench to make a 1/4 turn to secondary tighten. When using commercial joints, use the M5 screws. Follow the joint maker's instructions for torque tightening and working method. When installing any joint, press the rear plate and take care to not apply excess force to the plastic part of the main unit. The piping is a flexible tube so ensure that it has support and does not pull on the main unit.

Accessory joint material: main unit: C3604BD nickel plating  
(GC30-111) packing: PVC

- Installation when using panel adaptor (optional)

Insert adaptor 1 from the front into the panel cutout, then insert the main unit from the back into adaptor 1 until the feet snap into the depressions in the GC30' s plastic part. Attach adaptor 2 to the main unit from behind and push until there is no gap left.

(Note: When installing in a panel in succession, leave at least 8mm space between each cutout.)

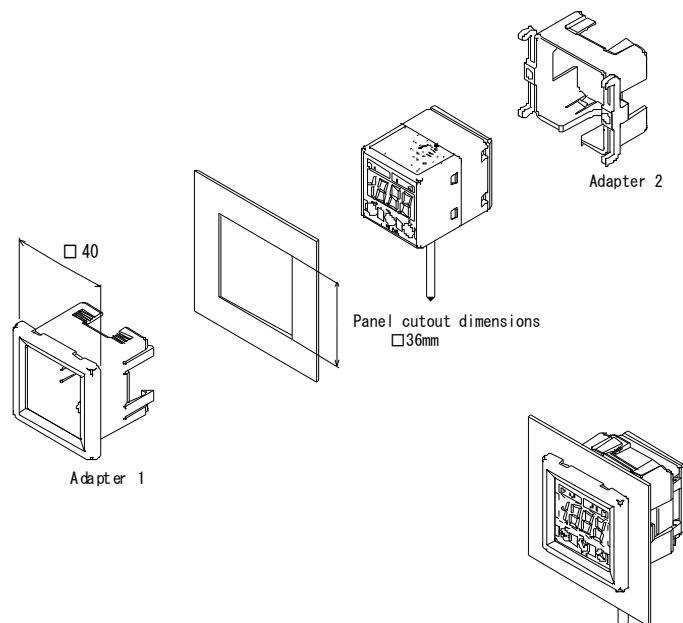

- With clamp installed (option)

Use the accessory M3 iron screw to install the L clamp, tightening torque is less than 0.3 N·m.

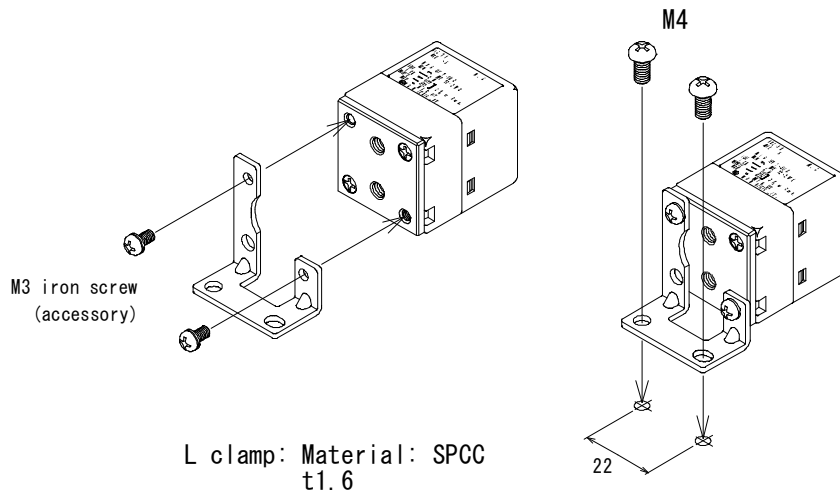

## 4. Connection

- Wiring

The cabling wire colors are as shown below. Connect power only after checking wiring. After power is turned on, wait at least 15 minutes before performing a zero point adjustment or measurement.

- |          |                         |
|----------|-------------------------|
| ▪ Brown  | Power ( + )             |
| ▪ Blue   | Power ( - ) · COM       |
| ▪ Orange | Analog output ( + )     |
| ▪ Black  | Open collector output 1 |
| ▪ White  | Open collector output 2 |

● Internal system

Output system is consists of an NPN open collector output for the comparator output.  
Analog output is 1~5V DC voltage output.

1) Analog output wiring example

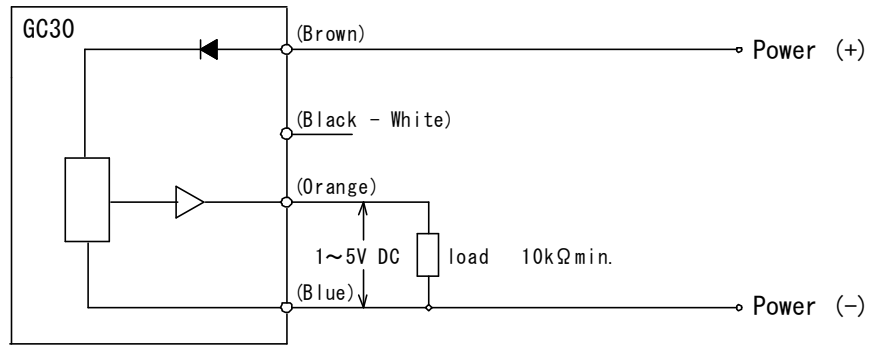

2) Using the open collector example (wiring to relay)

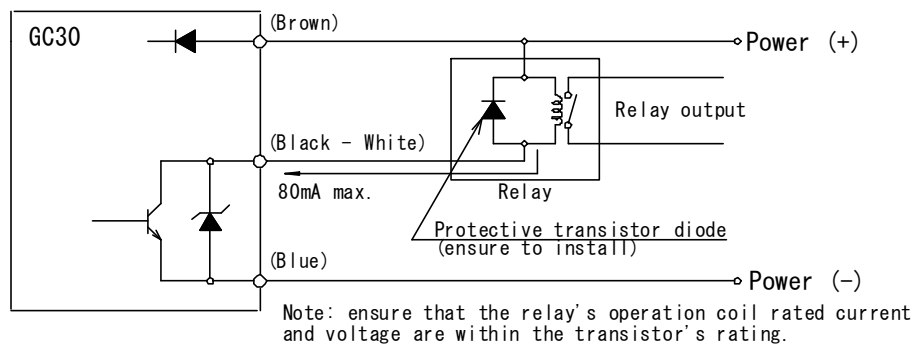

3) Using the open collector example (wiring to photo coupler)

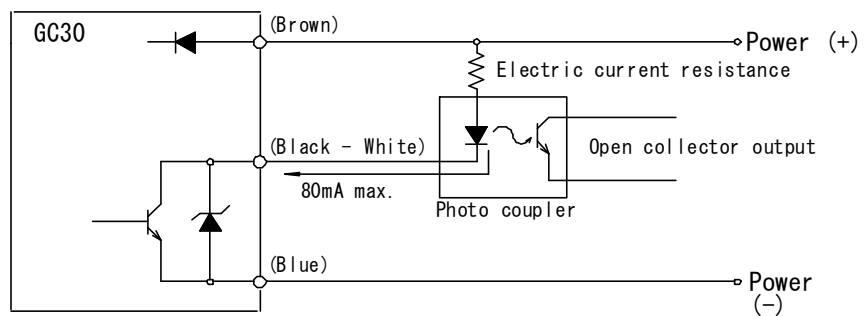

4) Using the open collector example (voltage output)

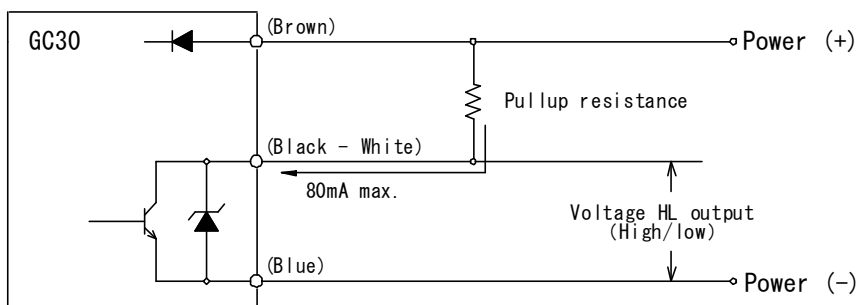

## 5. Noise prevention

- Power line

When noise remains in the power line, the pressure display can fluctuate and malfunctions can occur. Take care not to tangle the AD/DC power line, and use a power line with a high noise rejection ratio. In addition, use a stable power source that will not cause ripple voltage.

- Induction noise

As a result of induction from outside sources, malfunctions can occur. In this case, separate from the noise source, change direction, and use a magnetic shield or an electrostatic shield.

## 6. Storage location

 <b>Note</b>	Do not store in the following places as damage can result. <ul style="list-style-type: none"><li>● Any place that water can reach.</li><li>● Any place where there can be a negative influence of atmosphere, temperature, humidity, sunlight, dust, salty or sulphuric air.</li><li>● Any places where there is vibration or shock (including during transportation).</li><li>● Any place where chemicals are stored or where there are releases of gas.</li><li>● In direct sunlight or inside a hot vehicle.</li></ul>
---	---

## 7. Maintenance

In this unit, although there are no moving parts in the sensing element and circuit components, according to working conditions it is possible that deterioration with age can occur so a twice yearly inspection is recommended. A zero adjustment should also be performed regularly. The GC30 case contains plastic parts so ensure it does not come in contact with a soldering iron etc. Chemicals can have an adverse effect on the case so ensure that none come in contact.

## 8. How to move to each mode

### ● Each mode and its function

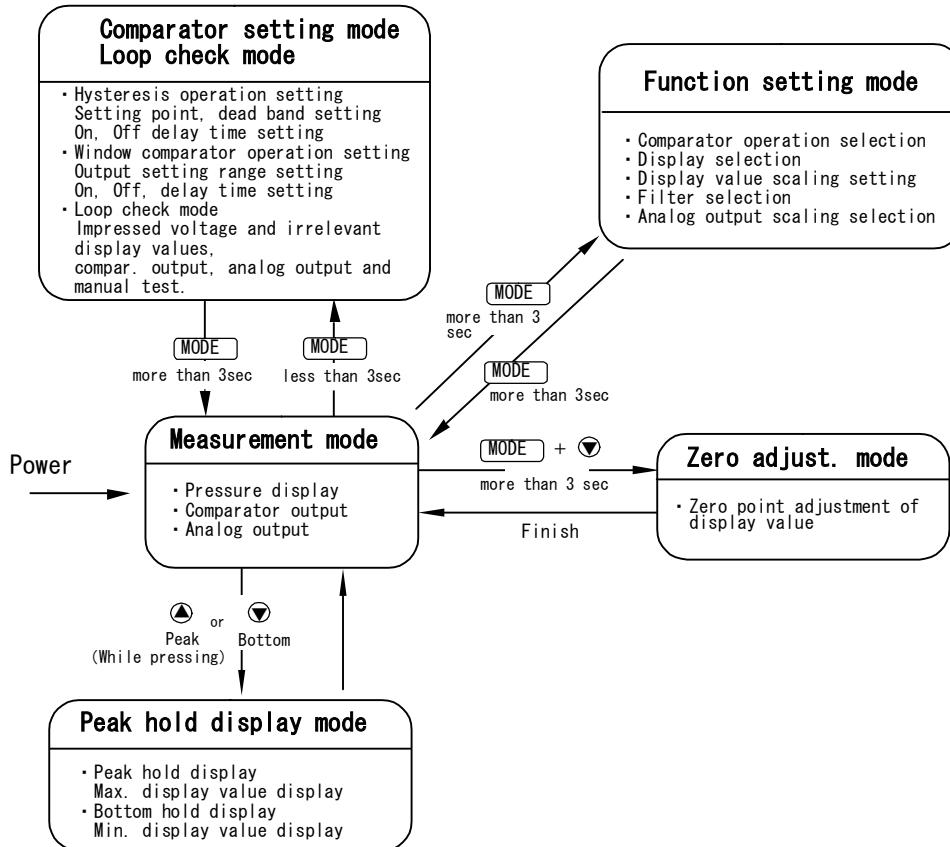

Pressing the **MODE** key for 3 seconds displays “---”. To return to measurement mode from each setting mode, the “---” display will flash when 3 seconds have passed.

### ● Names on Panel and functions

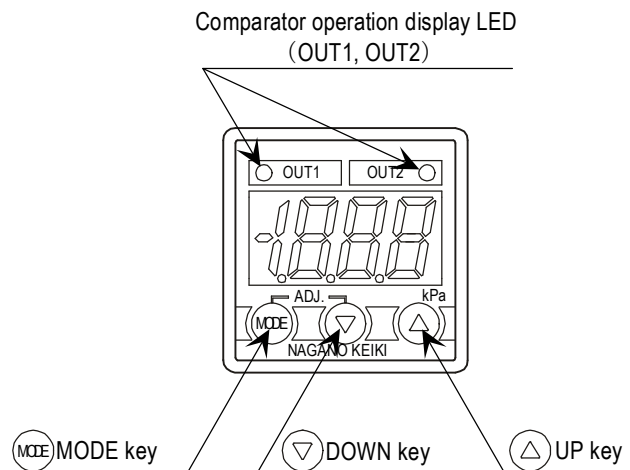

Do not use sharp objects to press the keys as this can put holes in the panel.

## 9. Function setting mode

### ● Setup steps

Pressing the **MODE** key for 3 seconds displays “---” and changes to function setting mode.

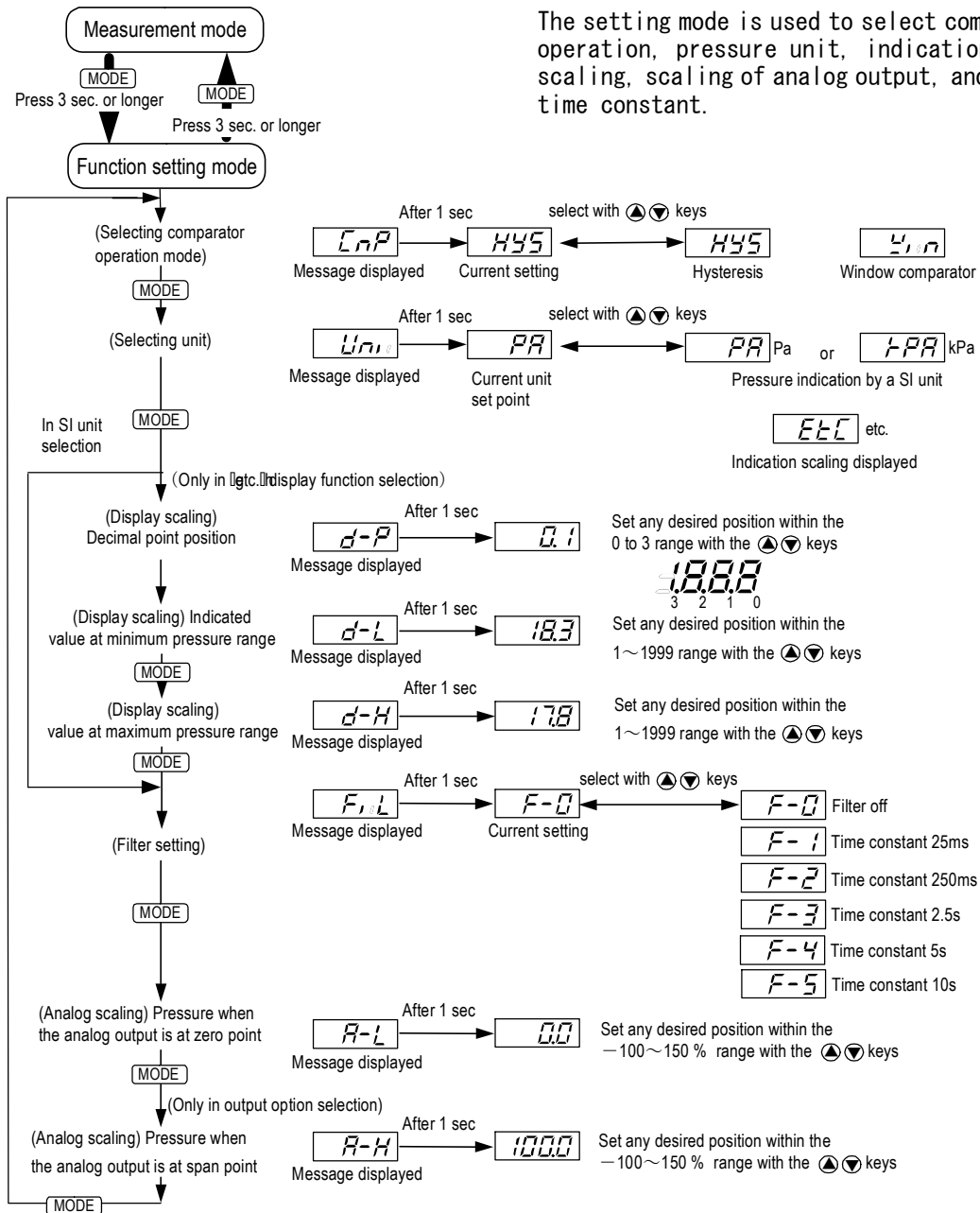

Entering the setting value in function setting mode resets all of the setting values including the comparator. Please note that when the reset setting values are out of the display range, they will be adjusted to a upper or lower limit value that can be processed internally.

- Comparator operation selection

Select “Comparator Operation Selection” with the **MODE** key. The message **Comp** is displayed for 1 sec. and then the current setting is displayed. Select either hysteresis or window comparator operation display with the Up/Down keys.

- Display selection

Select “Display Selection” with the **MODE** key. The message **Unit** is displayed for 1 sec. and then the current setting is displayed. Select pressure display by a SI unit (Pa or kPa) or display scaling display with the Up/Down keys.

Pressure range and the display max.

Pressure range		Diff. press. display max.		Display Scaling etc.
		Pa	kPa	
0 ~ 50 Pa	±50 Pa	50.0	-	
0 ~ 100 Pa		100.0	-	
	±100 Pa	100	-	
0 ~ 200 Pa	±200 Pa	200	-	
0 ~ 500 Pa	±500 Pa	500	-	
0 ~ 1 kPa		-	1.000	
	±1 kPa	-	1.00	
0 ~ 2 kPa	±2 kPa	-	2.00	
0 ~ 5 kPa	±5 kPa	-	5.00	

\* When compound range, negative pressure displays with a minus sign.

- Scaling of LED display

When **E<sub>LL</sub>** is selected in “Display Selection”, the LED display value for applied pressure displays as an arbitrary scaling display. This is a function is to scale the min/max pressure value for LED display and has no effect on applied pressure and analog output.

Select “Display Scaling” with the **MODE** key. The message **d-P** is displayed for 1 sec. and then the current setting mode’s decimal point position is displayed. Change the decimal point position value with the Up/Down keys.

The pressure range minimum value can be set in the same way using the **MODE** and **▲▼** keys. The pressure range min/max display values are stored internally as operation coefficients. Hereafter, in “Display Scaling” **E<sub>LL</sub>** is selected, these coefficients are used for scaling and LED display.

Ex.) With a pressure range of 0~500 Pa (0~100% F.S.), main unit display of 0~500 is changed to a display of 0.0~10.0.

**d-P** Dec. point position (from least significant digit): 0 → 0.1

**d-L** Min. pressure range value: 0 → 0.0

**d-H** Max. pressure range value: 500 → 10.0

- Filter selection

The GC30 is equipped with 5 internal time constant filters. Use this function when pressure fluctuations can result in erratic, difficult to read displays. The time constant for the selected filters reflects on the comparator as well as analog output.

Select “Filter Selection” with the **MODE** key. The message **F<sub>L</sub>** is displayed for 1 sec. and then the current setting mode’s decimal point position is displayed. Change the decimal point position value with the Up/Down

keys.

<b>F-0</b>	-----	No filter
<b>F-1</b>	-----	Time constant 25ms
<b>F-2</b>	-----	Time constant 250ms
<b>F-3</b>	-----	Time constant 2.5sec
<b>F-4</b>	-----	Time constant 5sec
<b>F-5</b>	-----	Time constant 10sec

- Analog output scaling

This mode is for setting the pressure for the analog output zero point (1V DC)/span point (5V DC).

Select “Analog Scaling” with the **MODE** key. The message **A-L** is displayed for 1 sec. and the current pressure's analog output zero point (1V DC) is displayed as a percentage. Change the numeric value with the Up/Down keys.

The analog output span point's **A-H** pressure can be set in the same way using the **MODE** and **▲▼** keys.

Ex.) With Analog output of 1 to 5VDC at pressure range of 0 to 100Pa (0 to 100%F. S.), output is changed to 1~5V DC at 0~98.1 Pa.

**A-L** Press. at time of analog output zero point: 0.0% F. S. →0.0% F. S.  
(1V DC output with pressure range 0% F. S.)

**A-H** Press. at time of analog output span point: 100.0% F. S. →98.1% F. S.  
(5V DC output with pressure range 98.1% F. S.)

## 10. Comparator setting mode / Loop check mode

- Setup steps

In measurement mode press the **MODE** key (release within 3 secs.) to change to Comparator setting mode / Loop check mode.

- Comparator setting mode

The comparator has both OUT1 and OUT2 points. Both “Hysteresis (upper/lower limit)” and “Window comparator” operations can be selected in the function setting mode (comparator operation selection). Those two operations can be selected at once, and can be set. Both OUT1 and OUT2 can be set independently to a max on/off delay of 2 seconds. In the following explanation, if the comparator’s output conditions are met their output state will become On, and “Comparator LED (OUT1, OUT2)” will light up.

Please note that if the comparator’s setting value is set outside the display range, the comparator’s setting value can be rewritten automatically by the function setting mode operation.

- Loop check mode

Regardless of applied pressure, display and analog output can be tested manually using the **◀▶** keys. Please use it for a simulation test of the analog output and comparator output wiring. After the comparator setting press **LOP** for 1 sec. to change into Loop check mode. The initial value will be the value displayed immediately before entering Loop check mode.

Use the **◀▶** keys to change the display value manually. Analog output and comparator output also change with the display value.

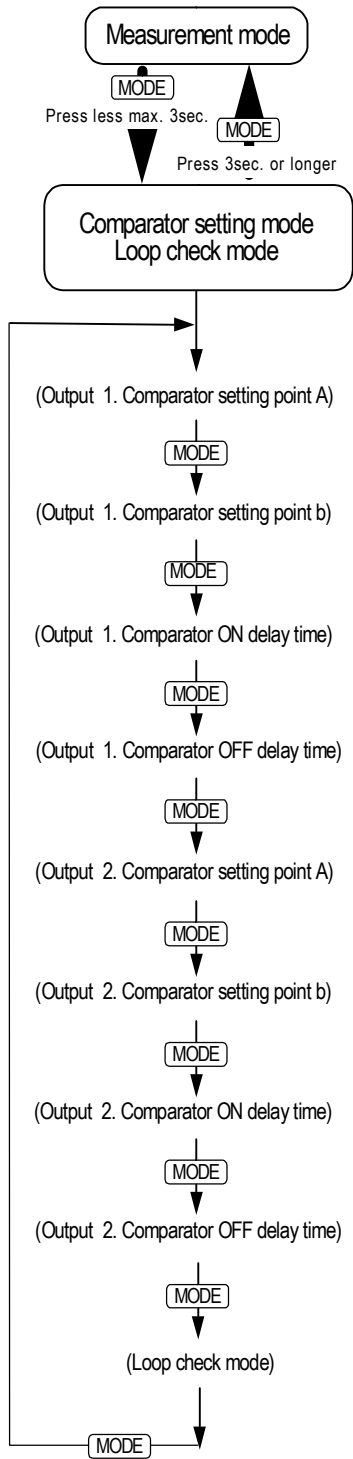

Message displayed **A-1** After 1 sec. → **900** Set any desired value within the —1999 to 1999 range with ▲▼ keys

Message displayed **b-1** After 1 sec. → **100** Set any desired value within the —1999 to 1999 range with ▲▼ keys

Message displayed **on1** After 1 sec. → **0.00** Set any desired value within the 0 to 2.00 sec range with ▲▼ keys

Message displayed **of1** After 1 sec. → **2.00** Set any desired value within the 0 to 2.00 sec range with ▲▼ keys

Message displayed **A-2** After 1 sec. → **500** Set any desired value within the —1999 to 1999 range with ▲▼ keys

Message displayed **b-2** After 1 sec. → **-100** Set any desired value within the —1999 to 1999 range with ▲▼ keys

Message displayed **on2** After 1 sec. → **0.10** Set any desired value within the 0 to 2.00 sec range with ▲▼ keys

Message displayed **of2** After 1 sec. → **1.00** Set any desired value within the 0 to 2.00 sec range with ▲▼ keys

Message displayed **LCP** After 1 sec. → **00** Simulate any desired input within the —1999 to 1999 range with ▲▼ keys

## 1 1. Comparator operation

- Operation of hysteresis mode

- Setting the upper limit.

This is the mode in which the comparator operates with the setting value (A) as the upper limit. The upper limit setting is determined when you select a positive number (including 0) for setting value (b).

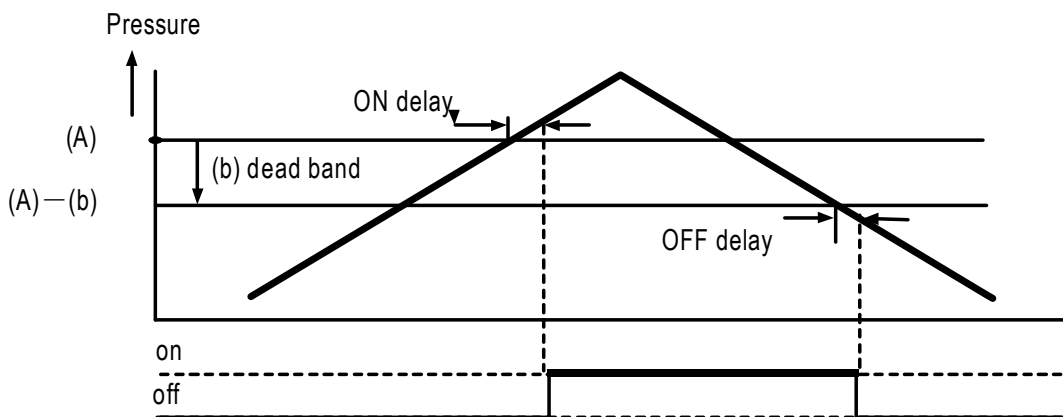

- Setting the lower limit.

This is the mode in which the comparator operates with the setting value (A) as the lower limit. The lower limit setting is determined when you select a negative number for setting value (b).

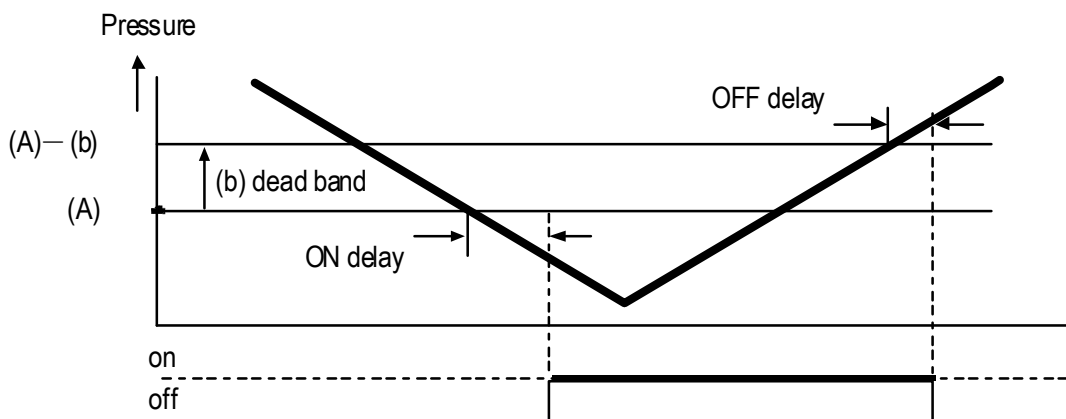

● Operation of Window Comparator

• For  $(A) \leq (b)$

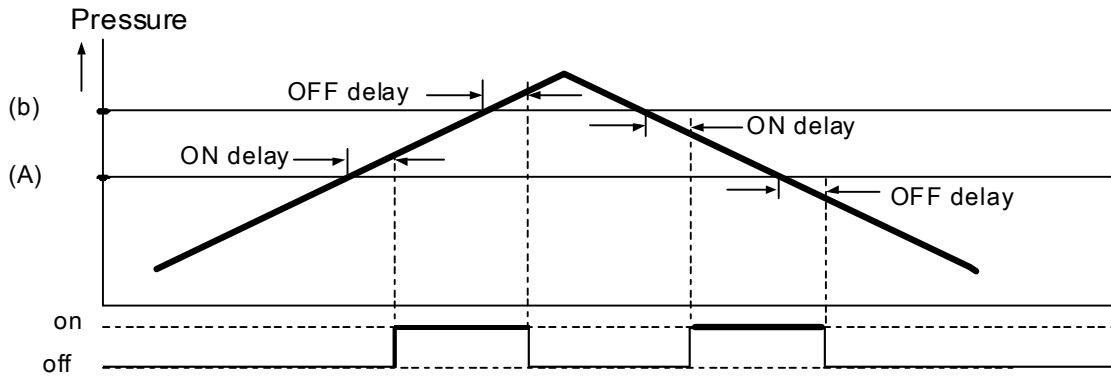

• For  $(A) > (b)$

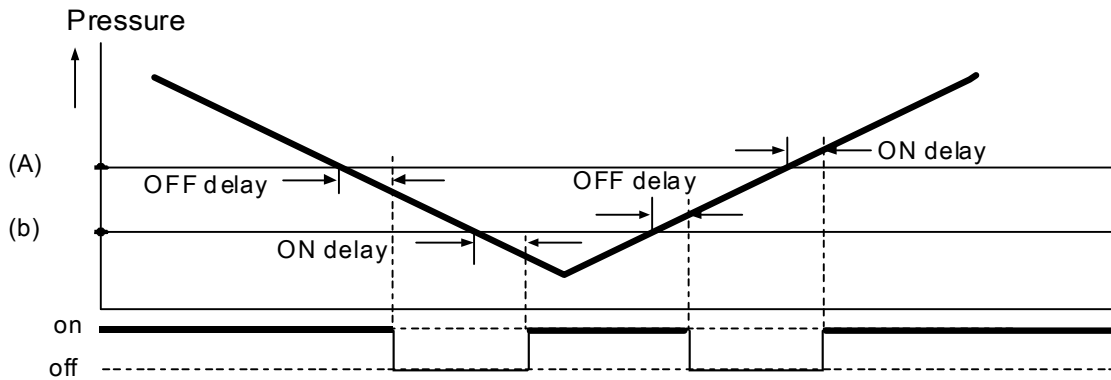

The 1% F.S. dead band is automatically set internally for setting point (A) and (b).

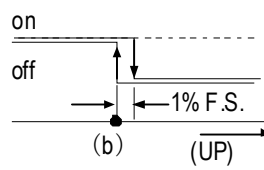
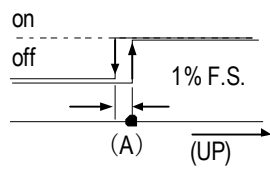

## 1 2. Other functions

- Basic key operations

In all setting modes, values are set with the ▲▼ keys. Use ▲ key to increase and ▼ key to decrease the value. A repeat state occurs in three phases of speed when the ▲▼ keys are pressed for more than 0.5seconds to increase or decrease numerical value. ▲▼ keys are also used for setting comparator, unit and filter in the function setting mode.

- Adjusting the zero point

In measurement mode, press the **MODE** + ▼ keys for more than 3 seconds (until “---” display blinks) after releasing pressure from the pressure port. Approximately 1 second later an automatic zero adjustment takes place and the pressure displays as zero. When the zero adjustment is successful, **Adj** displays. The error **E-0** displays for one second when applied pressure was outside the range of -10~10% F. S. , zero adjustment does not happen.

- Peak hold

The GC30 unit keeps the maximum and minimum pressure level applied to the pressure port as peak and bottom values respectively, in the internal memory. The peak and bottom values are displayed as long as press and hold the ▲ or ▼ keys respectively. When you select this operation, the message **PEH** is displayed for one second and selected Peak/Bottom value is displayed. Peak and bottom values are reset when you reset power to the unit, or by following procedure:

Resetting peak value: While holding the ▲ key, press the ▼ key .

Resetting bottom value: While holding the ▼ key, press the ▲ key .

- Key lock

Key operations can be nullified to prevent inadvertent overwriting of setting values. Once the key lock state is set, the function setting, comparator setting, zero point adjust, and loop check modes cannot be accessed. The key lock mode cannot be reset by turning the power OFF and ON. It may be reset only by following the unlocking procedure.

Press the **[MODE]** + **[▲]** keys in measurement mode. The message **[LoL]** displays for one second, indicating that the unit has entered into the key lock state. To reset, press the **[MODE]** + **[▲]** keys again. The message **[UnL]** displays for one second indicating that the unit is unlocked.

- Error display

An error message and a pressure are alternately displayed when one of the following errors occurs while in measurement or loop check mode.

Error display	Contents	Action
<b>[FFF]</b>	A pressure equal to or above 110% F.S. of sensor range is applied, or when indicated value exceeded 1999.	Return pressure to rated range.
<b>[-FFF]</b>	A pressure less than -10% F.S. of sensor range is applied, or when indicated value exceeded -1999.	
<b>[E-0]</b>	During zero adjustment, applied pressure is outside the range of $\pm 10\%$ F.S.	Open the unit to the atmosphere and adjust zero point again.
<b>[E1-]</b>	Comparator 1 is in overloaded state	
<b>[E-2]</b>	Comparator 2 is in overloaded state	
<b>[E12]</b>	Comparator 1 & 2 are in overloaded state	

- Backup of setting values

The unit has an internal EEPROM to maintain settings and the key lock state during a power interruption.